

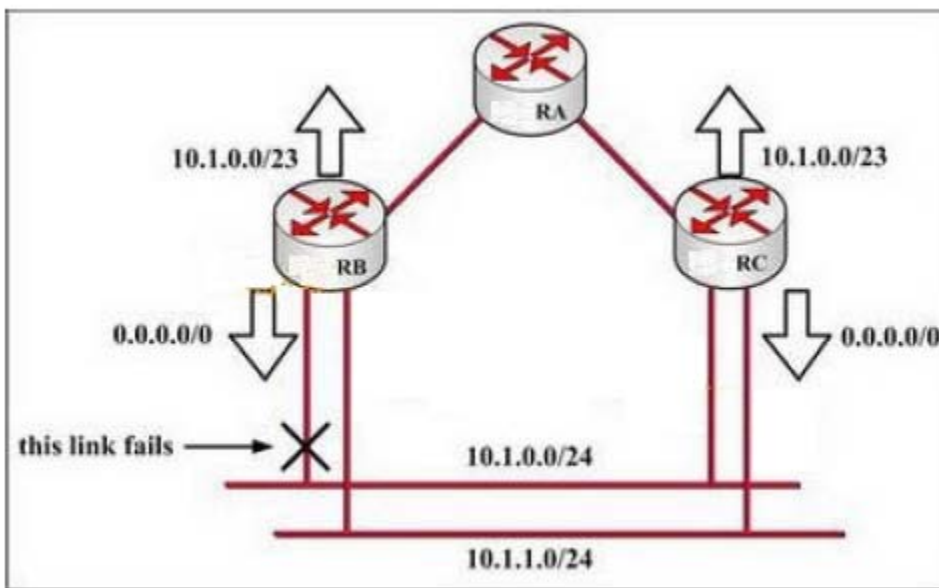

**Cisco**

**351-001**

*CCIE Routing & Switching Written Exam*



- A. Router P4S-RA will redirect traffic destined for hosts attached to 10.1.0.0/24 towards router P4S-RC.
- B. Any traffic router P4S-RA sends to router P4S-RC that is destined for a host attached to 10.1.0.0/24 will be dropped at router P4S-RC.
- C. Any traffic router P4S-RA sends to router P4S-RB that is destined for a host attached to 10.1.0.0/24 will be dropped at router P4S-RB. Since router P4S-RA cannot determine if router P4S-RB's link to 10.1.0.0/24 has failed, there will be a routing black hole.
- D. Nothing, the network will still work fine.

**Answer: C**

**Question: 230**

Connecting four routers running IS-IS to a single Ethernet link. Then, a fifth router is connected, the priority of this router is higher than that of the other four. What will happen?

- A. The new router will not be elected DIS unless the current DIS fails.
- B. The new router will become the DIS without causing a temporary disruption in traffic through the link.
- C. The new router will not be elected DIS unless it has the lowest NET ID.
- D. The new router will become the DIS and cause a temporary disruption in traffic through the link.

**Answer: B**

**Question: 231**

For the following mechanisms, which two could provide fast Layer 2 down detection in Frame Relay networks? (Choose two.)

- A. Asynchronous LMI
- B. Section 9 LMI convergence
- C. A-bit signaling
- D. Millisecond LMI timers

**Answer: A, C**

**Question: 232**

Which content networking device allows bandwidth configuration settings so that streaming content will not interfere with other network traffic?

- A. IP/TV Control Server
- B. Content Distribution Manager
- C. Content Engine
- D. IP/TV Broadcast Server

**Answer: A**

**Question: 233**

Which tool enables a network designer to route traffic according to the source IP address?

- A. Source routing
- B. MPLS Layer 3 VPNs
- C. policy-based routing
- D. Uncast Reverse Path Forwarding

**Answer: C**

**Question: 234**

Tom is a network administrator for the P4S Ltd. He is having problems with redistribution routing loops between two EIGRP processes. After studying the configurations, he determined there is no filtering configured on the routes being redistributed. In order to avoid having a single point of failure, there are three routers configured to redistribute between the two routing protocols. Which one of the following items is a solution to minimize management complexity?

- A. Replace one of the EIGRP processes with an alternate IGP
- B. Reduce the number of routers redistributing between the two routing processes
- C. Build and apply a route filter based on the networks being redistributed between the two processes
- D. Use tags to control redistribution between the two processes

**Answer: D**

**Question: 235**

Intermediate system to intermediate system (IS-IS), is a protocol used by network devices (routers) to determine the best way to forward datagrams through a packet-switched network, a process called routing. A client has approached you about deploying very fast IS-IS hello timers across an intercontinental high speed SONET link. What's your option?

- A. Fast hello timers are a good choice for this link because the length of the link indicates there will be at least one SONET amplifier that disables PATH alarms on the circuit.
- B. Fast hello timers are a good choice for this link because on long haul SONET links the reporting of LINE and PATH errors can take a long time.
- C. Fast hello timers are not a good choice for this link because the link is physically long and the propagation delay may cause IS-IS to believe the link has failed when it has not.
- D. Fast hello timers are not a good choice for this link because SONET links provide link-down notification much faster than IS-IS could detect a circuit failure by means of hello processing.

**Answer: D**

**Question: 236**

The Internet Group Management Protocol (IGMP) is a communications protocol used to manage the membership of Internet Protocol multicast groups. IGMP is used by IP hosts and adjacent multicast routers to establish multicast group memberships. What is the purpose of IGMP in a multicast implementation?

- A. it is used in multicast
- B. it is not used in multicast
- C. it dynamically registers individual hosts in a multicast group on a specific LAN
- D. it is used on WAN connections to determine the maximum bandwidth of a connection

**Answer: C**

**Question: 237**

The following exhibit shows the design of this redundant network which uses EIGRP as the IGP of choice. What is the advantage of using BFD in this design?

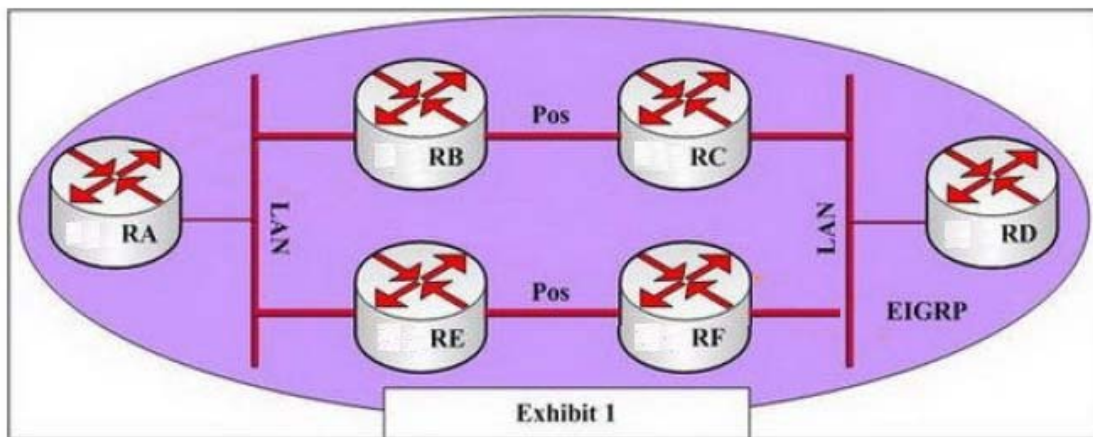

- A. Allows BFD peers to nominate feasible successors
- B. Improves the speed of failure detection and neighbor teardown
- C. Provides Layer 2 paths around failures, avoiding Layer 3 convergence
- D. Helps EIGRP disseminate routing information by means of BFD-elected peers

**Answer: B**

**Question: 238**

The following exhibit shows us that all the routers in this network are running EIGRP on all links. In Network 1, all links are the same cost. In Network 2, router P4S-RE prefers the path through P4S-RC, and does not have a feasible successor. Which network converges faster in the event of the failure of the link between router P4S-RA and 10.1.1.0/24?

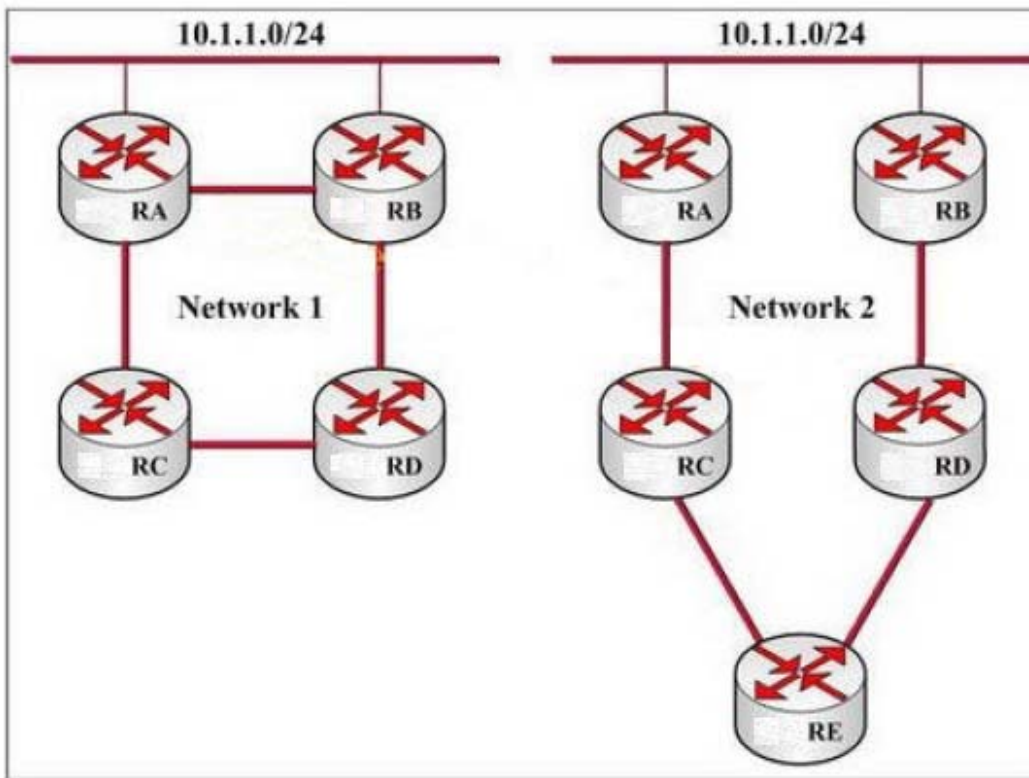

- A. Network 1, because there are fewer query hops through the network
- B. Network 2, because there are more alternate paths available
- C. Network 2, because routers P4S-RC and P4S-RD have feasible successors
- D. Network 1, because all routers have feasible successors in this network

**Answer: A**

Download Full Version From <https://www.certkillers.net>



**DON'T KNOW**  
OR NO PREFERENCE

*Pass your exam at First Attempt....Guaranteed!*